

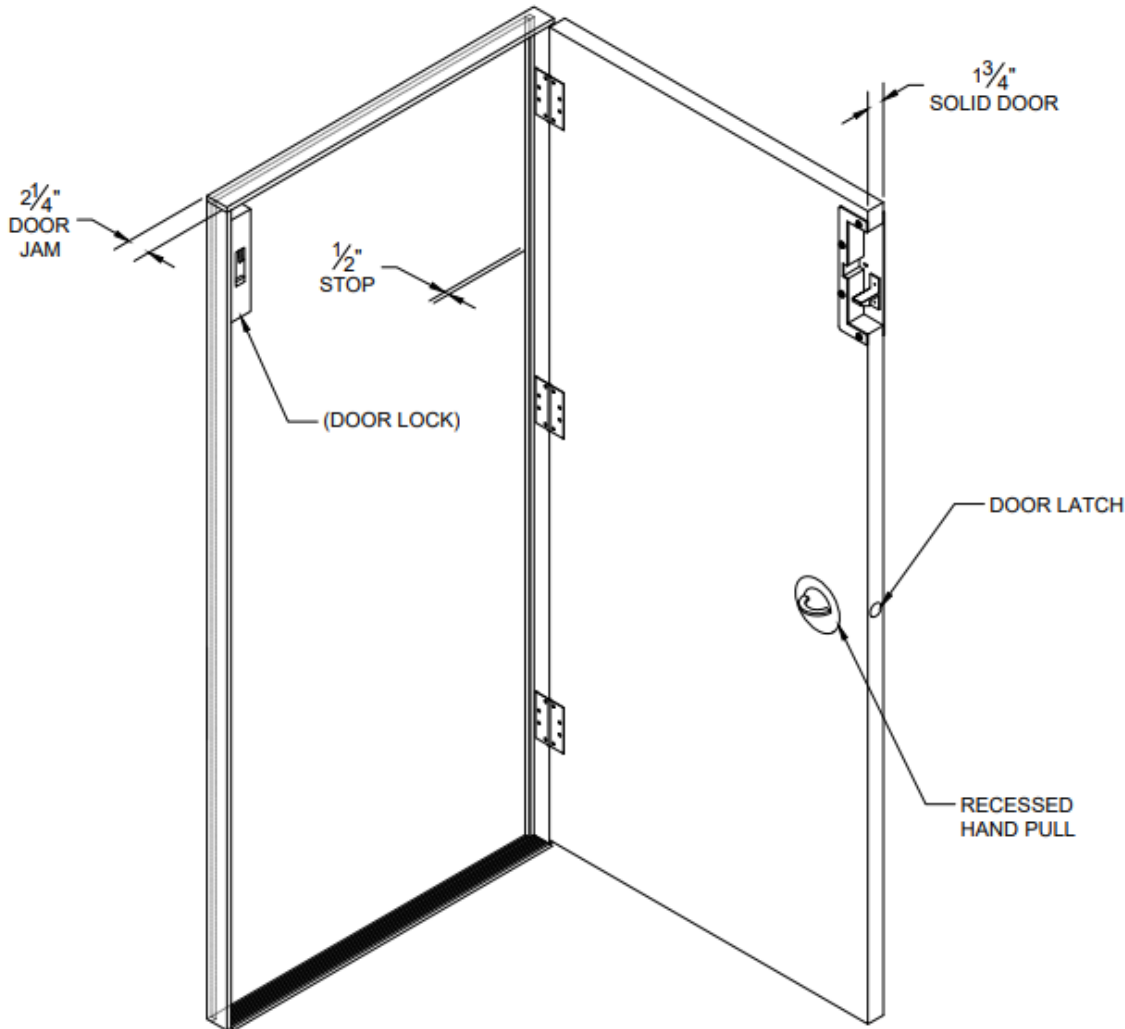

ACCREDITED
HOME ELEVATOR COMPANY

SET BACK KIT Specifications



Notes:

- 1 3/4" solid core door mounted to 2 1/4" door jamb with 1/2" stop.
- Doorknob Options: Contact your project manager for more details.
- The ball catch strike plate must be set on jamb so that when the door is closed, it sits flush against the jamb stop.

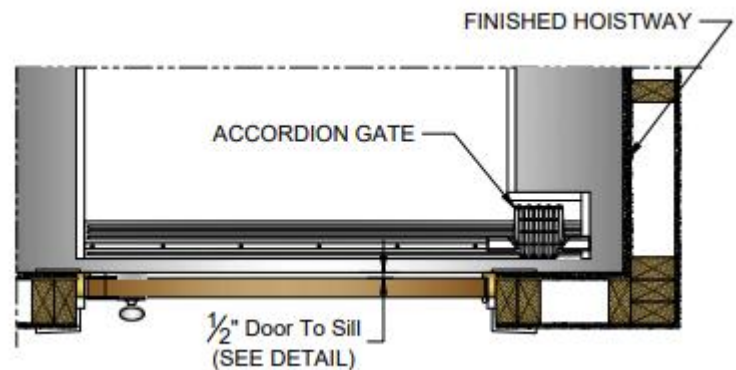

Accredited Home Elevator Company

www.accelelevator.com (800) 488 5905

AHE | 127 S Main Street Barnegat, NJ 08005 | marketing@accelelevator.com



ACCREDITED
HOME ELEVATOR COMPANY

SET BACK KIT Specifications

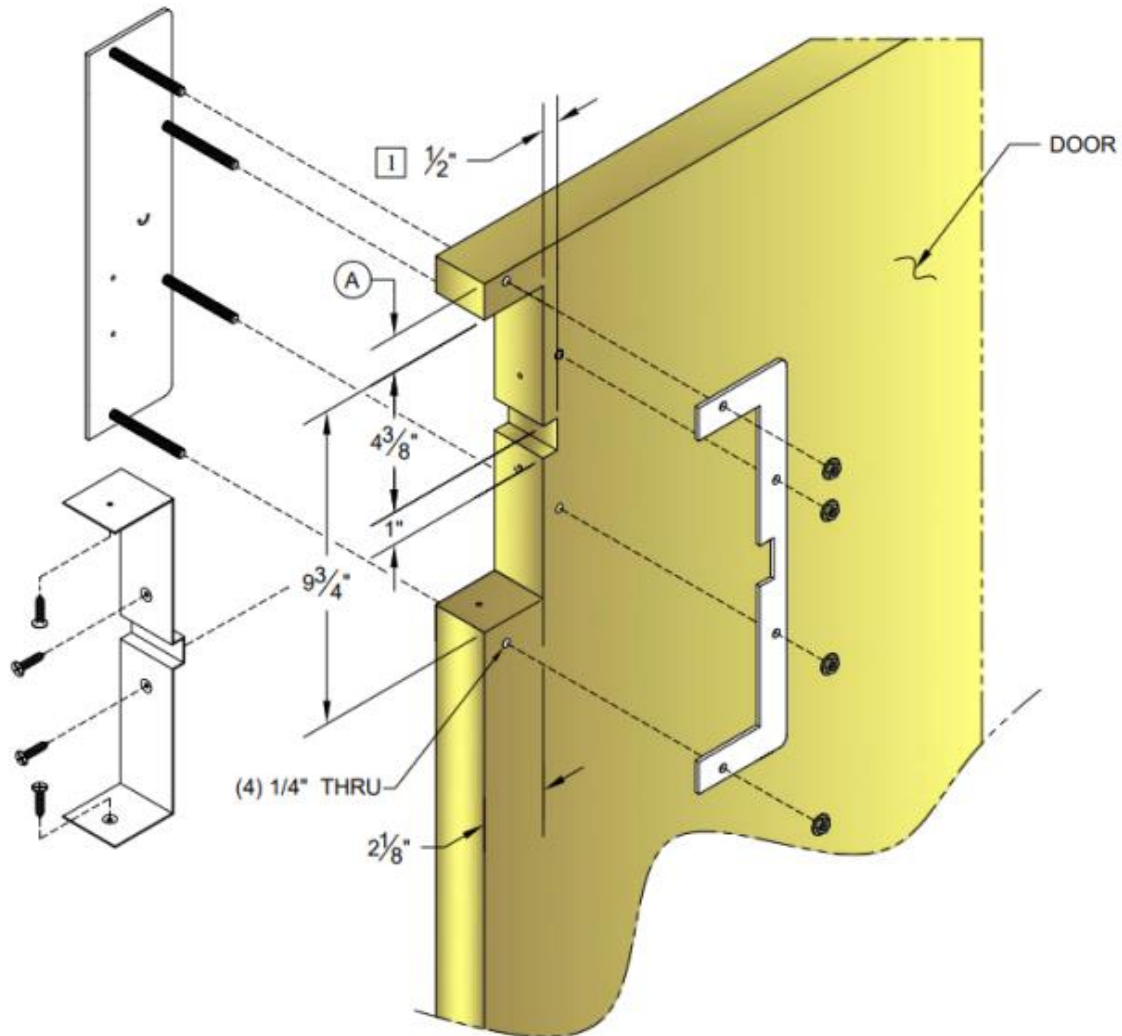

Door Height	A
80"	2"
84"	5"
96"	17"

Accredited Home Elevator Company

www.accelelevator.com (800) 488 5905

AHE | 127 S Main Street Barnegat, NJ 08005 | marketing@accelelevator.com



ACCREDITED
HOME ELEVATOR COMPANY

SET BACK KIT

Specifications

Plumbing of Hoistway Doors:

- For jurisdictions enforcing ASME A17.1 2016 and later, Doors must be 1 $\frac{3}{4}$ " Solid Core set on flush mount elevator jambs. See your elevator contractor for more detail.
- All doors must be installed inline and plumb with one another at each floor.

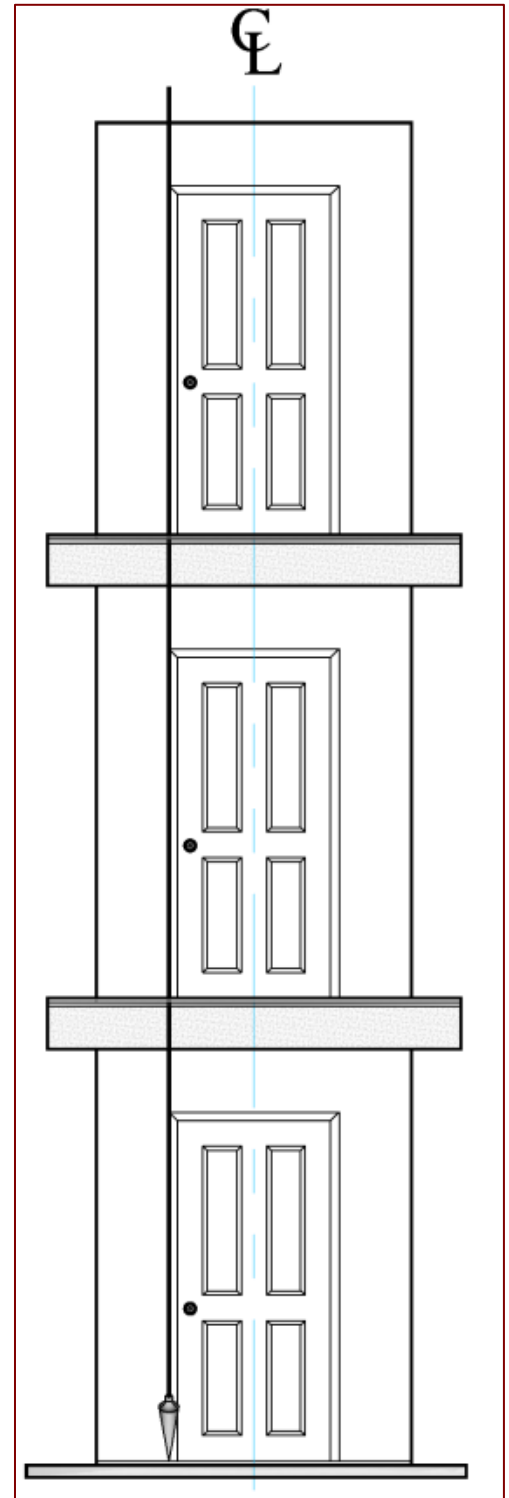

Accredited Home Elevator Company

www.accelelevator.com (800) 488 5905

AHE | 127 S Main Street Barnegat, NJ 08005 | marketing@accelelevator.com



ACCREDITED
HOME ELEVATOR COMPANY

SET BACK KIT Specifications

As Stated Per ASME 17.1 ($\frac{3}{4}$ " Rule) :

- The clearance between the face of the $1\frac{3}{4}$ " solid core door from inside the hoist way to the hoist way sill cannot exceed more than $\frac{3}{4}$ inches.
- The clearance between the face of the $1\frac{3}{4}$ " solid core door from inside the hoist way to the outside face of the gate on the elevator cannot exceed more than 4 inches.

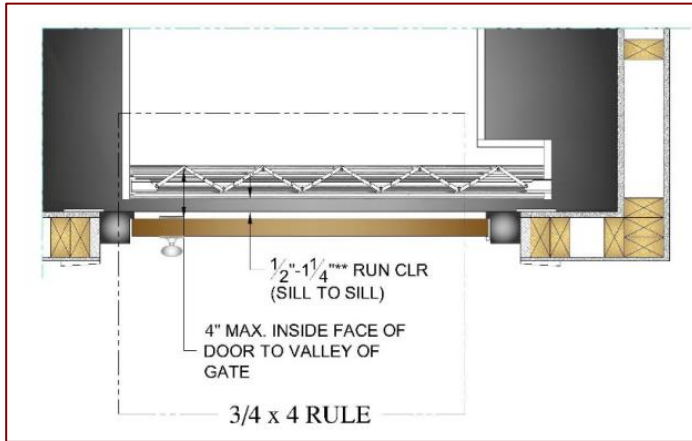

- Doors must be hung flush with the inside hoist way drywall leaving maximum $\frac{3}{4}$ " from closed door to inside edge of sill/drywall.
- Inner Hoist way door casing/trim is not to be applied until after the elevator device is installed.
- Clearance between landing floor and underside of hoist way door must not exceed $\frac{3}{8}$ ".

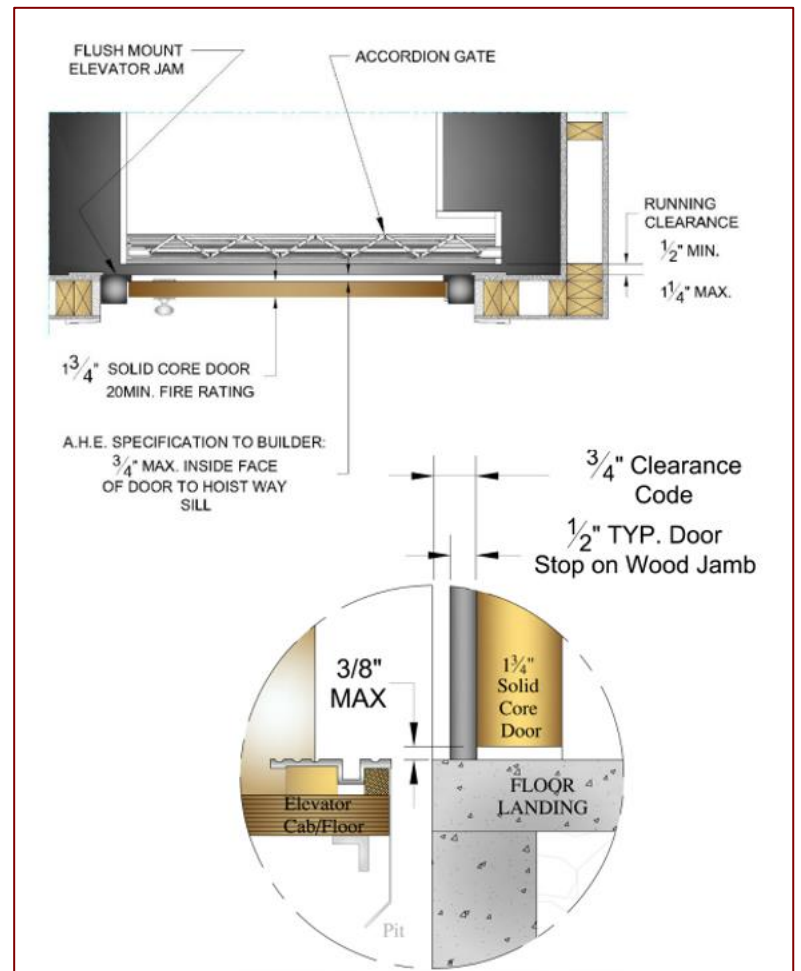

Accredited Home Elevator Company

www.accelelevator.com (800) 488 5905

AHE | 127 S Main Street Barnegat, NJ 08005 | marketing@accelelevator.com